

# Manipulating Carbon Nanotubes using attocube ANPxyz50 Positioners in a Scanning Electron Microscope

Attaching Carbon Nanotubes (CNTs) on metal tips is an attractive method for functionalizing tips or for further experiments on these nanoscale objects. This application note describes experiments on attaching such nanotube bundles onto a Tungsten tip in a scanning electron microscope (SEM) using attocube ANPxyz50/HV positioners. The setup consists of three positioning stages carrying the sample with the CNTs and the tip on a special adapter plate (see Fig. 1). On the left, one can see the ANPz50 positioner that carries the tip. On the right, two ANPx50 positioners with orthogonal orientation have been placed to position the sample. The tip is formed by an etched Tungsten tip, while the sample is a slotted silicon chip, across which CNTs have been synthesized in a floating CVD system.

The tip can be aligned with regards to the sample in all three dimensions, while the height of the sample stays constant with regards to the electron microscope to keep it focussed. Additional ground wiring has been attached to the positioners' bodies to avoid electrical charging due to the electron beam (it has to be noted that the attocube positioners due to their design are electrically isolating from the top to the base). The setup was directly mounted on the motorized sample stage of the SEM with the electrical wiring fed through a flange in the door of the SEM.

The workflow of the attachment was as follows: After identifying a thin bundle of CNTs across the slit, the tip was positioned close to the bundle in order to allow attachment by van der Waals forces. After tearing the bundle apart by subsequent tip retraction, a short part of the bundle was left attached to the tip (see Fig. 2).

In summary, it has been shown that the attocube systems ANPxyz50 positioners can easily be mounted into a commercial SEM for precise manipulation experiments. The orthogonal setup of the attocube ANPxyz50 positioners greatly facilitated the whole attachment process. Thin Carbon Nanotube bundles could be selected and attached to metal tips, thus enabling further experiments with these functionalized tips.

The experiments have been performed by Sebastian Stapfner, Song Li, and Eva Weig from the nanophysics group at the Ludwig-Maximilians-University of Munich (LMU).

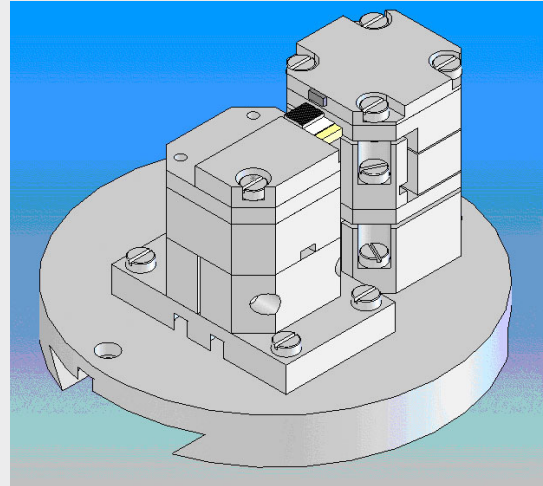

**Fig. 1:** Sketch of the setup. The positioners have been grouped as xy and z in order to minimize the height of the setup.

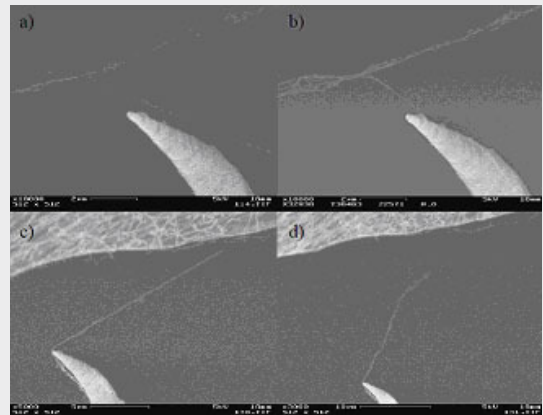

**Fig. 2:** Process of attaching a Carbon Nanotube bundle: a) bringing the tip close to the bundle. b) bundle attaches to the tip by van der Waals forces, c) and d) the bundle ruptures as the tip is moved away.

### RELATED PRODUCTS

ANPxyz50/HV	ultra compact, high precision, piezo electric, inertial positioners
ANC150/3	piezo step controller